

*Compu-Flow*TM

Electromagnetic Insertion Flow Meter



COMPU-FLOWTM

www.advancedflow.com

1-800-649-5331

INTRODUCTION:



When you need a reliable flow meter the Compu-Flow™ is the right choice. We have been manufacturing for the flow meter markets for the last 30 years.

Mag meters are the popular choice for closed pipe applications. The CEM100 model is the most advanced design in the industry for Low Profile Single Point Insertion mag meters.



This style of flow meter is the practical choice for virtually all full pipe applications. The CEM100 offers features often not found in even the most expensive spool piece models. Rapid response time, simple installation and removal, rugged design, and unmatched accuracy are just some of the advantages the CEM100 MAG offers. Combine this with our user friendly display and competitive pricing and you have a winning combination.

INTRODUCTION:



The basic kit of the C6 Compu-Flow™ Electromagnetic flow meter consists of a low profile insertion sensor and a display control panel.

A modular system of electronics can be attached directly to the flow sensor or remotely mounted. The meter provides full indication of rate and total, plus 4-20 mA, HiLo Alarms, RS232, and Batch Control.

The adapter of the CEM100 models, mates with a standard female NPT fitting, and can be directly threaded into ordinary saddles or threaded weld fittings. The standard sensor probe length is 12", optional custom probes: 6", 12", 18", 24" & 36" Lengths.

Models of 12" to 36" offer an isolation valve, allowing hot-tap installation, or installation and removal under pressure.

Now!!
Introducing the All
New Compu-Flow™
Smart-Mag Magnetic
Insertion Flowmeter



New features include:
Smart-LED Visual Flow
Indicators.

Your Flow at a glance!

Utilizes Smart-Flow
Technology exclusively by
Compu-Flow™

Compu-Flow™ introduces the technologically advanced industrial-grade magnetic single point insertion flow meter for superior flow measurement: The Compu-Flow™ Smart-Mag. The revolutionary new and enhanced hardware and software design results in a low-profile, high performance flow meter that delivers precise flow readings due to it's advanced proprietary microprocessing technology. Compu-Flow™ introduces the first in its class Smart-LED indicators to immediately know what your flow is doing at-a-glance. Stainless-steel probe with stainless-steel electrodes are mounted in teflon for extended service life. Upper housing and all hardware is either PVC or stainless-steel.

INTRODUCTION:

Smart Mag Features:

- **Quick & Easy Installation:** Installation time from start to finish is typically 30 minutes.
- **User-Friendly:** Engineered with an extremely easy to use interface. No math or formulas required.
- **High-performance:** Out-performs competition in accuracy and reliability. Guaranteed. NIST Certified to < 0.5%.
- **Compu-Flow™ Smart-Flow Technology:** Proprietary technology delivers best-in-class flow readings.
- **Compu-Flow™ Smart-LED Indicators:** Immediately know what your flow is doing at-a-glance.
- **Lightweight & Low Profile:** The Compu-Flow™ Econo-Mag is the first in its class to provide a revolutionary lightweight & low profile hardware design. The future of magnetic flow meters is here. Custom probe lengths optional.
- **Multi-industry clean flow measurement solution:** Engineered to measure virtually all water based flows in most industries.
- **Rapid Response Time:** Instant accurate flow readings. Get down to business, fast. Selectable update times.

Compu-Flow™ electromagnetic flow meters work under the Faraday law of electromagnetic induction. They can be used to accurately measure the flow rate of liquids which are electrical conducting, and mixed with liquids and solids. They are widely used throughout industries of petroleum, pharmacology, papermaking, electric power, environmental protection and so forth.

The main features of the control panel include:

- Smart LCD screen featuring high-resolution, 32 character, 2-line alphanumeric providing rate and totalization simultaneously, in Metric or English units.
- Splash proof NEMA 4X case protects from moisture and caustics.
- Easy configuration for set up and operation with on-screen prompting, quick scrolling menus, display panel keypad, and color coded LEDs.
- RS232 via DB9 PORT 9600 Baud.
- Batch Control, Isolated Output for Dry Contact Relay.
- Separate High and Low Alarm outputs for Dry Contact Relay with LED status.
- Data Logger 1 – 32 GB memory USB Flash Drive data transfer.
- Wireless Signal option from Sensors and/or Receiver (sensor singular).
- Optional signal cable lengths up to 5000 ft. No Tuning required.

INTRODUCTION:

- Great accuracy even in turbulent flows.
- Wide pipe diameter range 2 – 72 inches.
- Maintenance-modular construction simplifying field service.
- Non-volatile Flash Memory for installed parameters 99 yrs.

Operating Conditions:

- Ambient temperature: 0°-180° F (-17° - 82° C).
- Fluid temperature: 32°-200° F (0° - 93° C).
- Submersibility: Water proof up to 200 ft.
- Pressure: 200 psi (13.8 bar) @ 75° F.
- Applicable Fluid: Electrically conducting liquid.
- Electrical conductivity: 20 Microsiemens / cm².
- Pipe Range: 2" –72" ID.
- Flow Range: 0.01 – 30.0 fps. (0.03 – 9.00 m/sec)

Technical Parameters:

- Housing: IP68 molded housing with modular electronics.
- R/T Back Lit LCD UFMC6 Display Std.
- Power range 10-24 VDC, no fuses to change. Carbon Arc auto resettable circuit breakers, 1 million cycle avg. life. Fast acting break and quick reset.
- Digital signal: 5VDC proportional to flow @ 100 Hz/fps, 50/50 duty cycle.
- Signal LED output 5 VDC @ 10 mA with full pipe and flow.
- Update time: Selectable 1-3 at receiver.
- Fitting size: 1" Male NPT (CEM112 to 136); 1¼" Male NPT Ball Valve.
- Auto averaging: 30 sec.
- Frequency Output: 100 Hz /fps.
- Bar Graph Flow/mA output LCD indicator.
- Pulse Output: Square wave pulse, isolated, 3000 Hz @ 30 fps. Forward flow standard, reverse flow optional.
- Flow signal: 10 mA @ 5 VDC Green Wire.
- K factor Default: 100 Hz/fps. Adjustable 1-256.
- Empty pipe detection: Software defaults to zero flow.
- Voltage output 1-5 VDC proportional to flow selectable.
- Hi&Lo Limit Alarms user select output to solid state relays.

Technical Parameters: (cont.)

- Communication: RS232 Receiver output DB9 / USB cable.
- Data Logger with USB memory and SD card platforms.
- Accuracy: 1% of full scale.
- Supply power: 12 VDC @ 1.0 A minimum.
- Housing material: ABS injection mold.
- Shaft/Fitting made of: 316 SS.
- Electrode Material: Hastelloy.
- Electrode cap material: Teflon, Mylar or Nylon.
- Valve assembly (CEM112 to 136): Bronze with SS ball valve.
- Nylon Tapered Ferrel Shaft Seal all models.
- Calibration accuracy: $\pm 1\%$ of full scale.
- Reverse flow rate output with indicator signal. Optional.
- Noise immune circuitry, very stable, not ground loop sensitive.
- Nominal formula for insertion depth: 12% of pipe ID.
- Virtually unlimited cable length with no tuning required. Signal Cable 25ft std. up to 1,000 ft w/o boost; 5,000 ft max.
- Simple 4 wire terminal connection with no tuning required.
- Digital signal output from the pipe. Unique stand alone sensor.
- Rugged construction. Quality components. SMT build format. Ultra reliable.
- Easily multiplexed to SCADA and PLC receivers.



CEM112SBV

CEM124SBV

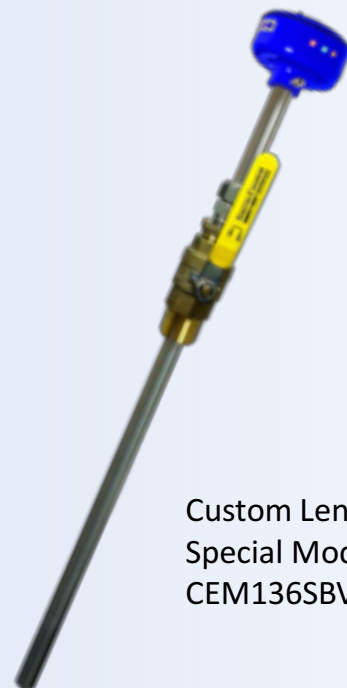
Custom Length
Special Model
CEM136SBV

INSTALLATION:

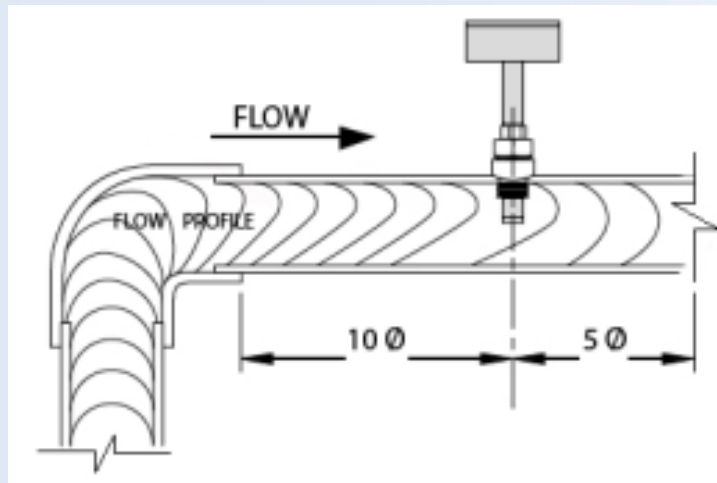

For best performance, the CEM sensor should be installed with at least ten diameters of straight pipe upstream and five downstream. Certain extreme situations such as partially-opened valves are particularly difficult and may require more straight diameters upstream.

Chemical Injection or Fertigation. When any magmeter, by any manufacturer, is used in a chemical injection application (including fertigation), the chemical line must be placed downstream of the magmeter OR far enough upstream for complete mixing to occur before the fluid reaches the meter. When unmixed chemical or fertilizer alternates with water passing through the meter, the rapid changes in conductivity may cause sudden spikes and drops in the meter's reading, resulting in inaccurate measurement. The magmeter will restabilize, however, with a steady flow of fluid of uniform conductivity. **Caution!** In chemical injection or fertigation applications, install chemical line downstream of magmeter, or far enough upstream to allow complete mixing of fluids before the meter.

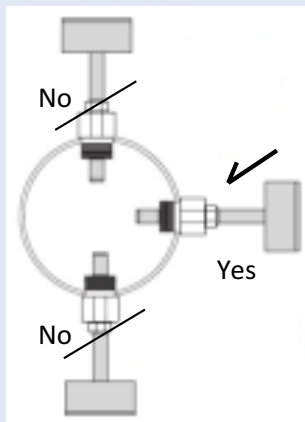

Position of the meter:

Vertical flow in upward direction is the preferred installation orientation, since it improves low-flow performance and avoids problems with trapped air and sediment. Bottom, top, and vertical pipe installations are all acceptable if required by the piping layout.

INSTALLATION:

Caution!: These flow sensors are not recommended for installation downstream of a boiler feedwater pump where installation fault may expose the flow sensor to boiler pressure and temperature. Maximum recommended temperature is 200°F.

Installation of CEM 112-136:

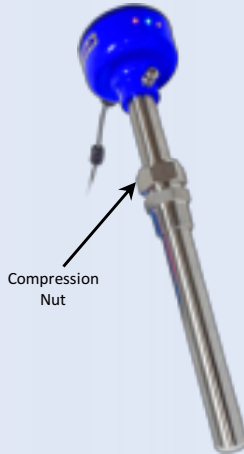

Fitting Installation. CEM adapters mate with a 1" female NPT pipe thread adapter fitting. Any fitting that provides the matching NPT female thread may be used. Installation procedure compensates for fitting height differences. Cut a minimum 1-1/4" hole in the pipe. If possible, measure the wall thickness and write it down for use in depth setting. Then install the threaded fitting (saddle, weldolet, etc.) on the pipe.

Meter Installation. Loosen the compression nut so that the adapter slides freely. Pull the meter fully upward and finger-tighten the compression nut. Using a thread sealant, install the adapter in the pipe fitting. Do not overtighten. Now loosen the compression nut, lower the meter to the appropriate depth setting (see diagram and instructions that follow). Be sure flow is in the direction of the arrow on the housing. Tighten compression nut fully.

Installation of 'Hot Tap' CEM 112-136:

'Hot tap' CEM meters are designed so they can be installed and serviced without depressurizing the pipe.

Fitting Installation. The CEM 112 thru 136 adapters mate with a 1 1/4" FNPT threaded fitting for compatibility with the 1 1/4" isolation valve. Any fitting that provides matching NPT female thread may be used. The installation procedure compensates for differences in fitting height.

If initial installation is performed on an unpressurized pipe, cut a minimum 1 1/4" hole in the pipe.



INSTALLATION:

Installation of (Hot Tap) CEM 112 thru 136: (cont.)

If possible, measure the wall thickness and write it down for use in depth setting. Then install the threaded fitting (saddle, weldolet, etc.) on the pipe.

If it is necessary to do the initial installation under pressure, any standard hot tap drilling machine with 1 ¼ " NPT adapter, such as a Transmate or a Mueller, can be used. Ordinarily, it is not necessary to use an installation tool, due to the small diameter tube the meter can be installed by hand at pressures under 20 PSI.

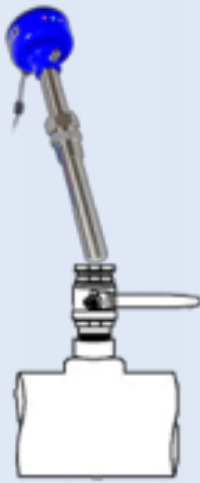

Meter Installation. Remove the sensor unit from the valve assembly. Using a thread sealant, install the valve assembly on the pipe fitting. If the initial installation is a pressure ("hot") tap, remove the 1 ¼ " x 1" adapter bushing at the back of the valve. Thread the tapping machine on, open the valve, and tap using a minimum of 1¼" or maximum 1-7/8" cutter. After retracting the machine and closing the valve, reinstall the flow sensor. When the sensor is secure, open the valve and adjust depth setting (see diagram and instructions that follow). Be sure flow is in the direction of the arrow on the housing. Tighten fitting and compression nut fully.

Depth Setting. It is important for accuracy that the sensor be inserted to the correct depth into the pipe.

1. Take dimension from reference point (joint in the housing) up to the tip of sensor.
2. From this whole dimension, subtract 12% of pipe I.D., and pipe thickness, to obtain dimension "D".
3. Measuring from the outside of the pipe to the joint in the housing, as shown in the diagram, adjust the sensor to Dimension D and hand-tighten compression nut.
3. Align the conduit housing with the centerline of the pipe. Be sure the arrow on the housing points in the direction of flow.

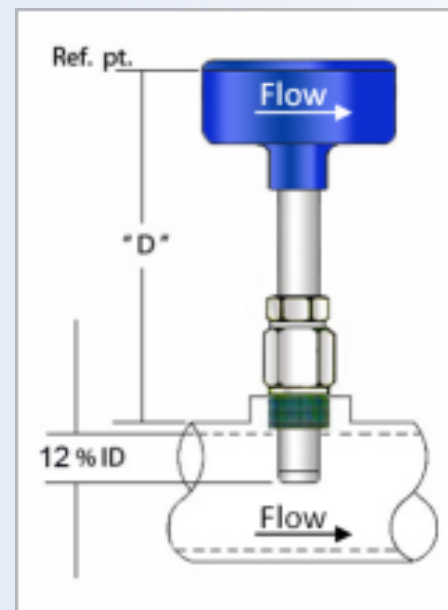

INSTALLATION:

Depth setting: (cont.)

4. Check Dimension D one more time.
5. Tighten the compression nut fully.

Caution! Never attempt to remove a flow sensor when there is pressure in the pipe unless it is specifically designed for hot tap installation and removal. Loosen the compression nut slowly to release any trapped pressure. If fluid sprays out when removing the sensor, stop turning and depressurize the pipe. Failure to do so could result in the sensor being thrown from the pipe, resulting in damage or serious injury.

Table 1: Pipe Wall Thickness

	NOMINAL PIPE SIZE												
	3"	4"	6"	8"	10"	12"	14"	16"	18"	20"	24"	30"	36"
PVC/Steel Sch.40	0.216	0.237	0.280	0.322	0.365	0.406	0.438	0.500	0.562	0.593	0.687		
PVC/Steel Sch.80	0.300	0.337	0.432	0.500	0.593	0.687	0.750	0.843	0.937	1.031	1.218		
Stainless Steel(10S)	0.120	0.120	0.134	0.148	0.165	0.180	0.188	0.188	0.188	0.218	0.250	0.312	0.312
Stainless Steel(40S)	0.216	0.237	0.280	0.322	0.365	0.375	0.375	0.375	0.375	0.375	0.375	0.375	0.375
Copper Tubing (Type L)	0.090	0.110	0.140	0.200	0.250	0.280							
Copper Tubing (Type k)	0.109	0.134	0.192	0.271	0.338	0.405							
Brass Pipe	0.219	0.250	0.250	0.312	0.365	0.375							
Duct. Iron (Class 52)	0.280	0.290	0.310	0.330	0.350	0.370	0.390	0.400	0.410	0.420	0.440	0.470	0.530

INSTALLATION:

Minimum Straight Pipe Length Requirements

The meter's accuracy is affected by disturbances such as pumps, elbows, tees, valves, etc., in the flow stream. Install the meter in a straight run of pipe as far as possible from any disturbances. The distance required for accuracy depend on the type of disturbance.

Type of disturbance	Straight Lengths of Pipe Required	
	Upstream from transducers	Downstream from transducers
Flange	5 X Nominal Pipe Size	5 X Nominal Pipe Size
Reducer	7 X Nominal Pipe Size	5 X Nominal Pipe Size
90° Elbow	10 X Nominal Pipe Size	5 X Nominal Pipe Size
Two 90° Elbows - 1 Direction	15 X Nominal Pipe Size	5 X Nominal Pipe Size
Two 90° Elbows - 2 Directions	20 X Nominal Pipe Size	5 X Nominal Pipe Size
Gate valve or Pump	25 X Nominal Pipe Size	5 X Nominal Pipe Size

- The meter can be mounted on horizontal or vertical runs of pipe.
- Avoid mounting on vertical down flows when possible.
- Mounting on the sides (3 o'clock and 9 o'clock) position on horizontal pipe is recommended.
- Mounting anywhere around the diameter of vertical pipe is acceptable, however, the pipe must be completely full of fluid at all times.
- Back pressure is required on downward flows to ensure a full pipe.
- See the minimum straight length of pipe requirement chart above.
- The meter can accurately measure flow from either direction.

Best recommended (✓) spots to install flow meters:

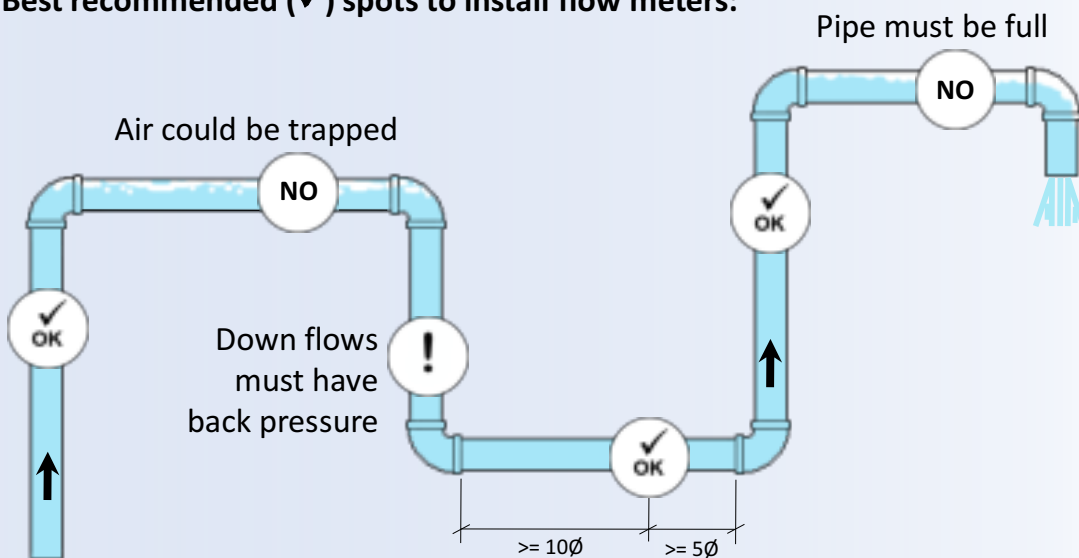

ELECTRICAL CONNECTIONS:

Transducer wiring:

If your electromagnetic sensor is not yet connected to the electronics control panel, open the panel, and use the next figure as a guide to make the proper wiring for the 4 transducer cables: Black (-12VDC), Red (+12VDC), Green (Echo), White (Signal).

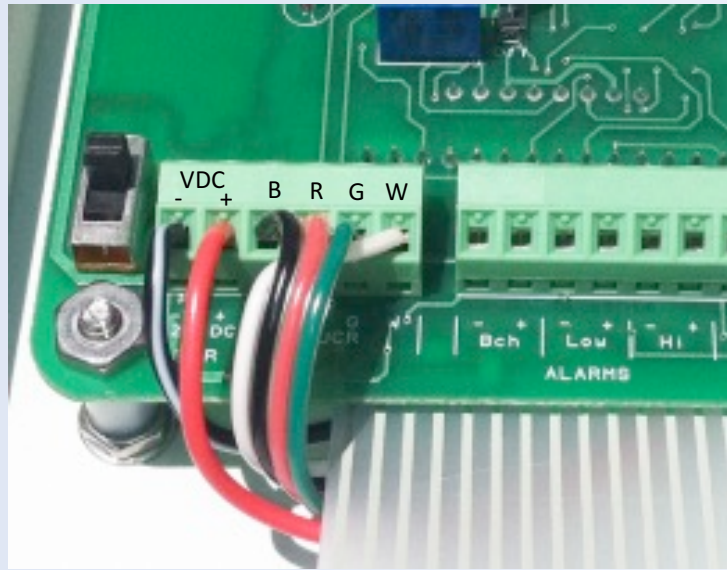

General Electrical Guidelines:

- Whenever possible avoid running control cables in the same conduit with or bundled with AC power.
- Using shielded cable, be sure to connect shield to ground at power supply end of the cable.
- Avoid routing flow sensor cables in close proximity to a variable frequency drive when possible.
- Recommended power and output wiring is shielded twisted pair 18-22 AWG control cable.
- Recommended voltage is 12-24 Vdc. Note that unregulated power supplies can vary from nameplate voltage by a considerable amount, especially with AC line voltage fluctuation. Therefore 24V power supplies must be regulated.

Output: The CEM sensor output is a 0-5V square wave digital pulse train proportional to flow @ 100Hz/fps .

Note: The CEM power requirement is 120mA@12VDC .

ELECTRICAL CONNECTIONS:

Grounding Guidelines:

For best results, use a good quality earth ground, such as metallic water piping or a driven ground, to ensure a good connection to earth ground and good noise suppression.

If the flow sensor is installed in metallic piping, for optimum connection clamp wire to the piping a short distance to one side of the flow sensor using an electrical grounding clamp. Connect the wire to the earth ground and to one of the housing screws. For Non-Metallic Pipe: Connect one to the housing screws by wire to a good earth ground, such as metallic water piping or a rod driven into the ground.

CEM meters are usually unaffected by moderate levels of electrical noise. In some applications performance may be improved by taking the following steps:

- Use shielded twisted pair cable (Belden 8723 or equivalent above ground or Alpha 35482 or equivalent burial).
- Clamp a ferrite bead (Steward 28A2029-OAO or equivalent) on meter signal/power wire within 3/4" of the meter strain relief (tape or tie wrap in place if necessary). See diagram below.
- **IMPORTANT** - Connect the cable shield ground wire to ground, **ONLY** at power supply end of cable.

Grounding diagram:

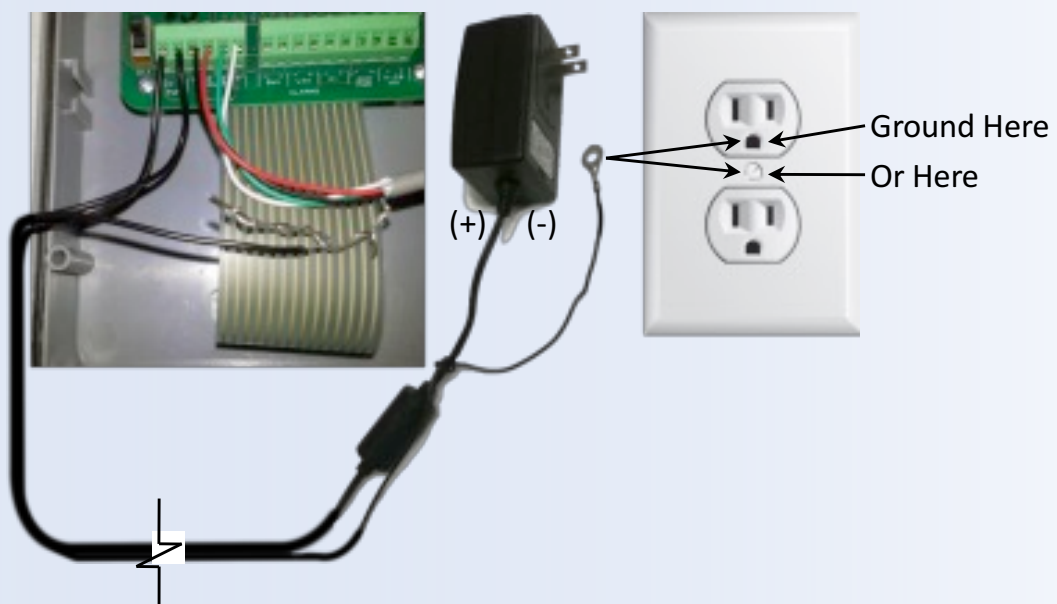

COMPU-FLOW™

“Smart-Mag” Wire Connection Guide

Compu-Flow™ CEM100 MAG

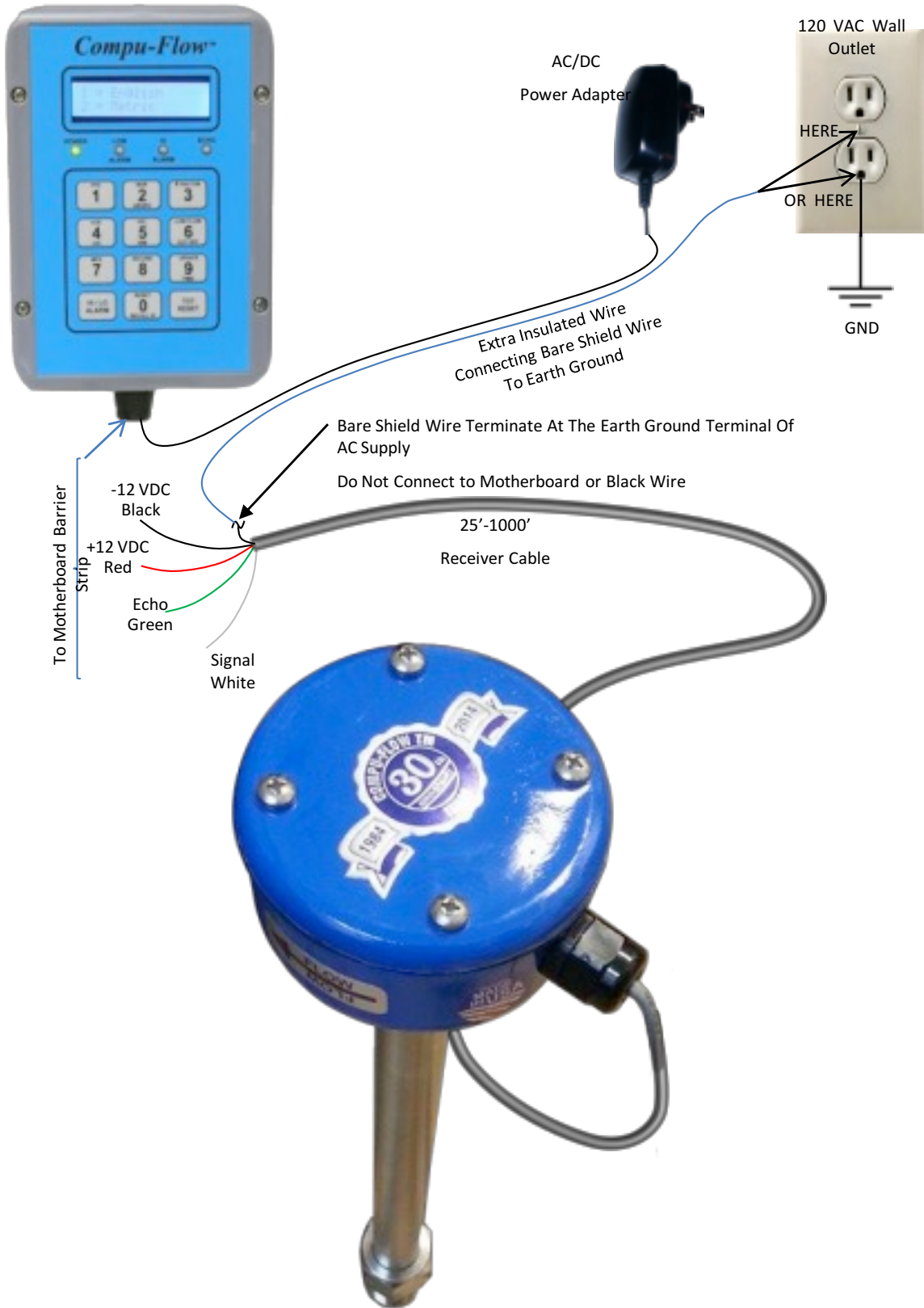

TROUBLESHOOTING

Problem: No pulse output

Probable cause:

- Unit not grounded
- Below minimum flow cutoff
- Flow reversed
- Output connections reversed
- Pipe not full
- Excessive electrical noise
- No power
- Power reversed
- Fluid conductivity <20 microSiemens/cm

Try:

- Connect to earth ground
- Check the Presence of Flow
- Note flow direction arrow, reverse direction to meter
- Change output connections
- Check plumbing
- Check for proper electrical wiring
- Check for power across power input terminals
- Reverse connections
- Select another flow meter

Problem: Output pulses incorrect

Probable cause:

- Missing or incorrect ground wire
- Incorrect depth setting
- Fluid conductivity <20 microSiemens/cm
- Empty pipe
- Not enough straight pipe
- Excessive electrical noise

Try:

- Check for proper ground
- Check depth setting page
- Select another flow meter
- Check for full pipe or install meter in the vertical position
- Check for air pockets or turbulence. Refer to installation page
- Check for proper electrical wiring

Problem: Jumpy reading

Probable cause:

- Rapidly changing conductivity (in chemical injection or fertigation applications)

Try:

- Install chemical injection line downstream of magmeter (or far enough upstream to allow complete mixing of fluids before meter)

PROGRAMMING



To Operate Your Flow Meter for the First Time:

1. Complete all the steps in “Installation” pages.
2. Turn on power and observe the display panel LCD. The display will show the model name and number of the unit.
3. Following the prompts presented by the display panel LCD, and making your entries using the keypad, configure your unit for operation for English or Metric.
 - The LCD screen displays SELECT RATE. Select the unit of measure for rate display: All rate selections may be displayed in seconds, minutes, hours, days. Time elements: (1=Sec 2=Min 3=Hr 4=Day)

Table 2. Rate selection - English

Key	Selection	Definition
1	FPS	Feet per second
2	GAL	Gallon
3	CF	Cubic feet
4	MG	Million Gallons
5	AF	Acre Feet
6	BL	Barrel 42 gal
7	MPS	Meters per second
8	LT	Liter
9	CM	Cubic meter

PROGRAMMING

If you select FPS, the flow meter will automatically begin measuring flow in feet per second. If you select keys 1 through 6, the LCD screen will ask that you enter your pipe ID in inches. If you select keys 7 through 9, the LCD screen will ask that you enter your pipe ID in millimeters.

After you enter your rate time element, the LCD screen will then display SELECT TOTALIZER. Select the unit of measure for totalizer display:

Table 3. Totalizer selection

Key	Selection	Definition
1	GAL	Gallons
2	CF	Cubic feet
3	MG	Millions of gallons
4	AF	Acre feet
5	BL	Barrels 42 gal
6	LT	Liters
7	CM	Cubic meters

After you enter your totalizer selection, the LCD screen will then display Enter Pipe ID. If you select keys 1 through 5, the LCD screen will ask that you enter your pipe ID in inches. If you select keys 6 through 7, the LCD screen will ask that you enter your pipe ID in millimeters.

Your CEM flow meter is now configured to measure the flow parameters you have set. After you set the flow reading parameters you need for your system, you can secure these settings so they are saved in the event of power loss to the electronics enclosure.

Note: To clear the rate and totalizer parameters you have set, select “0” reset or switch the power off using the on/ off switch on the display panel. Until settings are saved using Key # 8, “Secure On”, the security switch, turning off power clears all previously set parameters. When you turn on power again, the LCD screen will prompt you to restart programming.

PROGRAMMING

To Save Your Programmed Flow Reading Settings Using the Secure Function:

1. Complete setting the flow reading parameters.
2. Press and hold key # 8 for 5 seconds until “Secure On” appears on the LCD display.

Note: If you need to change your programming, press and hold key # 8 “Secure” until “Secure Off” appears on the LCD display.

If you wish to further customize your flow meter system for operation in your process, continue on to [“Advanced Configuration Options”](#).

Advanced Configuration Options

The display panel keypad has a secondary menu for advanced configuration options (the keypad toggle menu). You may want to use this menu to set 4-20mA analog output, set up bar graph, select HI/LO alarm set points, and configure batch control. To access the secondary menu, press appropriate key until the display changes. To exit, press the key again.

- [Figure 1](#) provides a visual representation of the toggle menu.
- [Table 4](#) lists the advanced configuration options accessible from the display panel keypad.

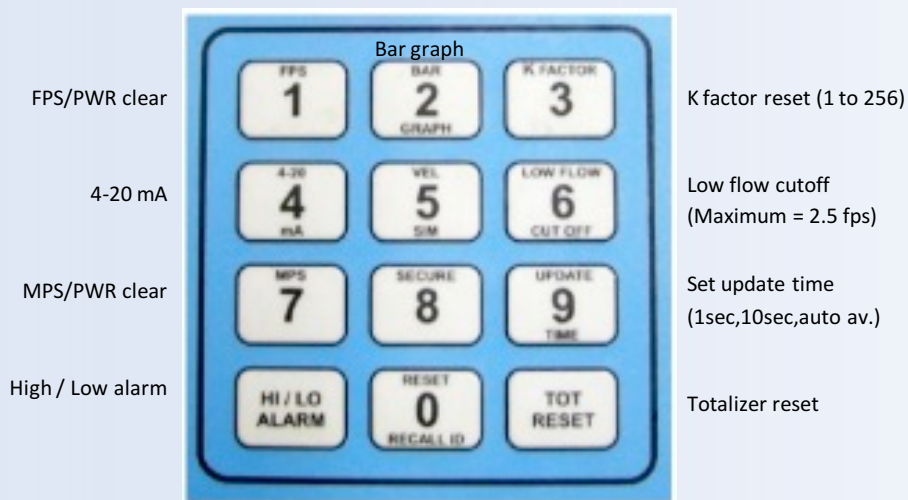

Figure 1. Display unit keypad

PROGRAMMING

Table 4. Keyboard Toggle Menu

Key	Selection	Functional Specifications
1	FPS	Feet per second/ clear pwr
2	Bar Graph	Analog 16 pt bar graph (n/a with batch)
3	K Factor	Select K factor while running
4	4-20 mA	Set up 4-20 mA analog output
5	Vel Sim	Velocity Simulator for systems test
6	Low Flow Cut Off	Set low flow cut off (maximum = 2.5 fps)
7	MPS	Meters per second/ clear pwr
8	Secure	Secure parameters On / Off
9	Update Time	Select update time: 1, 2, or 3
0	Reset / Recall Pipe ID	Recall pipe ID/ configure batch/ system reset
	HI / LO ALARM	Set up HI/LO limit alarms/ reset cursor
	TOT RESET	Reset totalizer while running/ reset cursor

Before Setting Advanced Parameters

The default setting for secondary keyboard functions is feet per second (fps), or meters per second (mps) if the flow meter is configured for metric units. Once the flow meter is operational and you wish to activate the analog bar graph, 4-20 mA output, batch control, high or low alarm, or low flow cut-off options, consult advanced parameter setting.

Sample parameter setting:

You have a velocity of 5 fps and you would like the 4-20 mA output to be 12 mA or 50% of scale. Push and hold the MA/4 key until the screen changes and then release the key. Enter a scale value of 10 fps via the keypad. The screen will automatically return the display to volumetric indication. The 4-20 mA output will read 12 mA at the terminal strip located on the right side of the main electronics circuit board. You may check your 4-20mA output setting via the bar graph.

PROGRAMMING

Note: Never adjust any of the potentiometers on the main processor board. These settings are to be performed by authorized personnel only.

SETTING ADVANCED PARAMETERS

This section explains how to set advanced parameters using the keyboard on the front panel of the unit.

Bar Graph

To Set the Analog Bar Graph of Flow Rate: (n/a with batch)

1. Press the Bar Graph/2 key. Enter the desired full-scale flow rate in the indicated engineering unit.
2. To return to the rate and totalizer flow reading, press the Graph/2 key again.
3. To return to the graph, press the Graph/2 key again and select OK.

Batch Control

1. To configure batch control press "0" key and select Batch.
2. Select Enable and choose 1=Pulse, 2=Batch.
3. Select Batch volume in preselected engineering units.

K Factor (Correction Factor)

The default K Factor on the Mag meter is set at 100 Hz/ fps for **Compu-Flow™** Sensors. For nearly all applications, this default K Factor setting should be adequate. There are only a few circumstances that might merit adjusting the default K Factor setting on your Electromagnetic flow meter.

Analog Output:

To Set the Analog Output:

1. Press the MA/4 key Enter the full scale preselected engineering unit.
2. After the output level has been set, the LCD screen will return to the rate and totalizer flow reading.

PROGRAMMING

Low Flow Cutoff

To Set the Low Flow Cutoff:

1. Press the FPS/1 or MPS/7 key to obtain the current reading in feet per second or meters per second. Press the key again to return to the flow reading parameters previously shown.
2. Press the LFC/6 key. Enter the cutoff in feet per second or meters per second. If you enter a parameter that is too high, the LCD screen will display the maximum allowable cutoff setting and then will return to the prompt for cutoff in feet per second.
3. After the low flow cutoff is set, the LCD screen will return to the rate and totalizer flow reading.

Meters per Second/ Power Clear

To Read Meters Per Second:

1. Press the MPS/7 key. The LCD will show the flow reading in meters per second on the upper line of the LCD screen, replacing the rate parameter previously on the screen. The totalizer reading remains the same parameter.
2. To return to the previous flow rate, press the MPS/7 key again.

Update Time

To Set Update Time:

1. Press the UT/9 key. To enter the selection screen.
1 = 1 sec 2 = 10 sec 3 = auto; "Auto" mode will update every second when the velocity change is >5%. When the flow stabilizes to < 5% change, the update time resets to a 10 second running average.
2. Enter the update time in 1 second, 10 seconds , or Auto.
3. After the update time is set, the LCD screen will return to the rate and totalizer flow reading.

PROGRAMMING

Hi/Low Alarms

To Set the High/ Low Alarms:

1. Press the HI/LO ALARM key. Select Hi, Lo, or Both. You may change the alarms one at a time without affecting anything else.
2. Next enter the high limit alarm in your preselected engineering unit.
3. Now enter the low limit alarm in your preselected engineering unit.
4. After the high and low alarm parameters are set, the LCD screen will return to the rate and totalizer flow reading.

Totalizer Reset

To Reset the Totalizer While the Unit is Running:

1. Press the TOT RESET key. The totalizer reading will return to zero.
2. The meter will begin taking totalizer readings from zero. The rate reading remains unchanged.

Compu-Flow™ CEM100 MAG

Table 5. Functional specifications

Description	Specification
Alarm output	AC: Separate Power module required for relay/ output Alarms & Batch
RS232 output	RS232 via DB9 & USB ports 9300 baud rate Terminal Emulation Software (HyperTerminal for Windows/ ZTerm for Mac)
Data Logger output	1-32 GB USB Flash drive USB board mount or remote cable
Power failure backup	Allows the electronics assembly to retain all parameter information and current totalizer value for 99 yrs
Standard interface	Specification
LCD display	2-line, 16 characters per line, high resolution, backlit
LED indicators	<ul style="list-style-type: none"> · Yellow: Echo signal received · Red: High alarm or low alarm activated · Green: Power available
Keypad	12 keys, tactile feedback Note: Keypad lockout via front panel keyboard; see “To Save Your Programmed Flow Reading Settings:” on page 16 and figure 1
Display panel	Rate selection, totalizer selection, K factor selection, analog output, low flow cutoff, update time (damping), high/ low alarm, fps, or mps selection, totalizer reset, etc
Output setting function	4-20mA output scaling (from keypad) in selected engineering units
Alarm setting function	High and low alarms set points (entered in engineering units)
Rate indication	4-digit LCD, velocity or volume (user selectable) English units: feet per second (fps), gallons (Gal), cubic feet (CF), and million gallons (MG), SMHD Metric units: meters (M), liters (LT), and cubic meters (CM), SMHD Note: Gallons refers to U.S. gallons, BBL=42gallon SMHD= Seconds, Minutes, Hours, Days
Totalizer indication	12-digit LCD English units: gallons, cubic feet, acre feet, barrels, and millions of gallons Metric units: liters and cubic meters Note: Gallons refers to U.S. gallons. BBL=42gallon
Update time (damping)	Entered from keypad 1sec – 10sec – Auto Running Avg (75%=1sec)
Low flow cutoff	0 fps to 2.5 fps (0 mps to 0.76 mps), entered from keypad
K factor	A value of 1 to 256, entered from keypad depending upon sensor type. The default is K=60 Hz (correction factor). For version C6 CEM sensor, K=100Hz.
Totalizer reset	Totalizer reset can be manually reset to zero from keypad
Key “#” function	Reset flashing cursor
“0” Key function	Resume- Reset ; Pipe ID- Batch
“8” Key function	Secure On/Secure Off
“5” Key test function	Test velocity simulator on/off
“2” Key function	Setup 16 point Bar Graph tracks 4/20mA output (n/a with Batch)

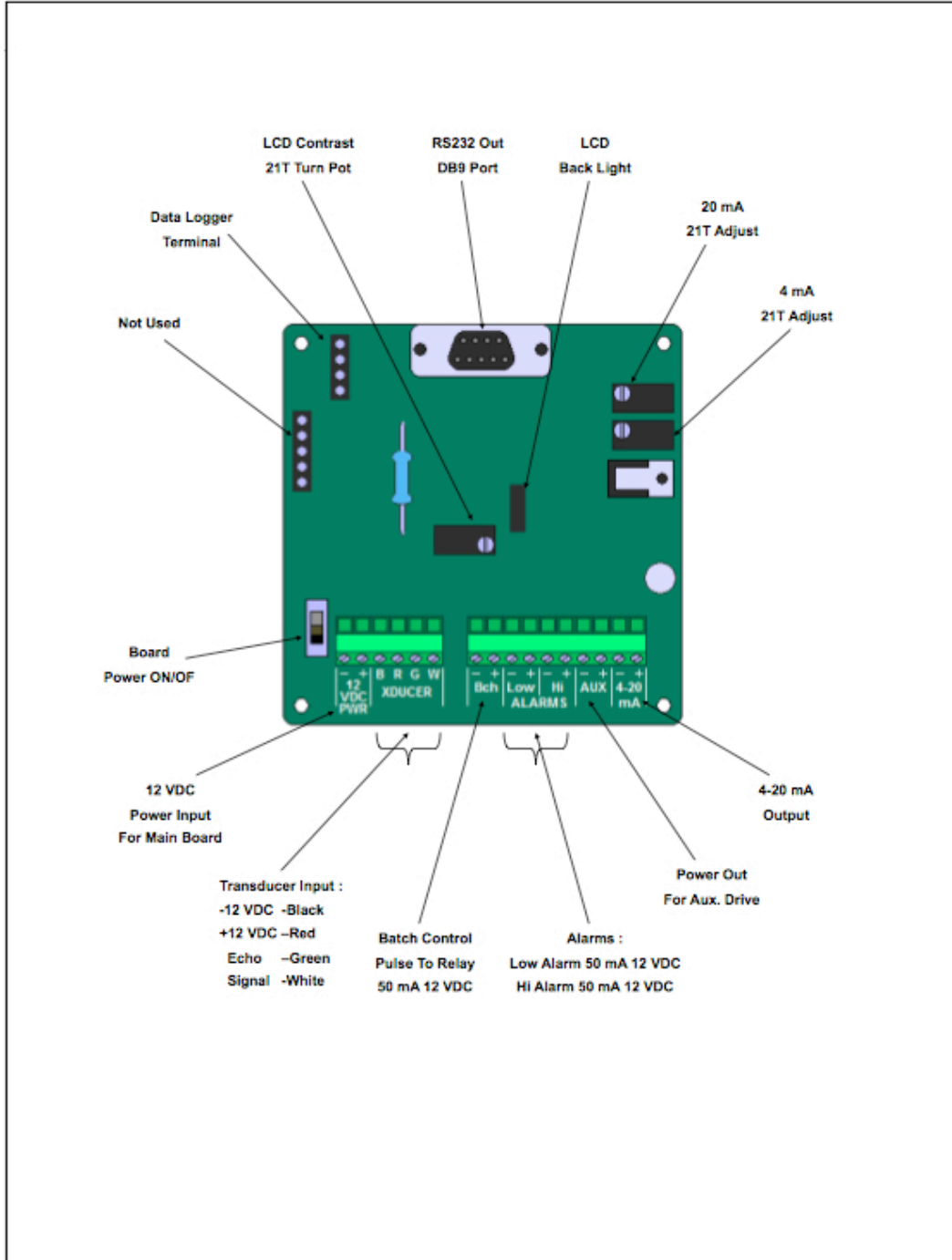

C6 M/B Wiring Guide

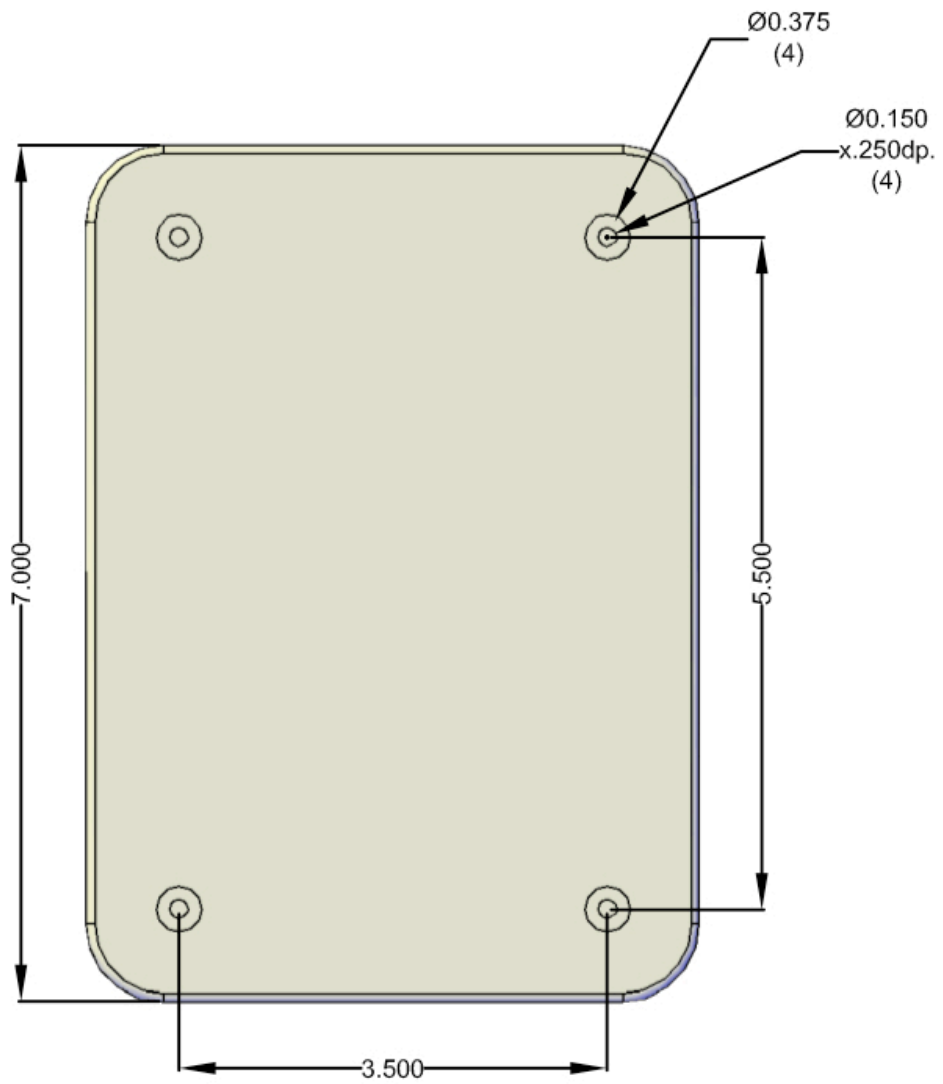

C6 Wall Mounht Dimensions

